



QHC18MR 18kW Heater Controller
3 channel (Receiver)
Remote & Manual Operation
Quick Start Guide & Instructions



Three phase 415v / Three Zone / Remote & Manual / Soft start

Quick Start for QHC18MR 18kW Heater Controller with Soft start Remote & Manual Operation.



Fig 1

QHVCR remote Master Controller

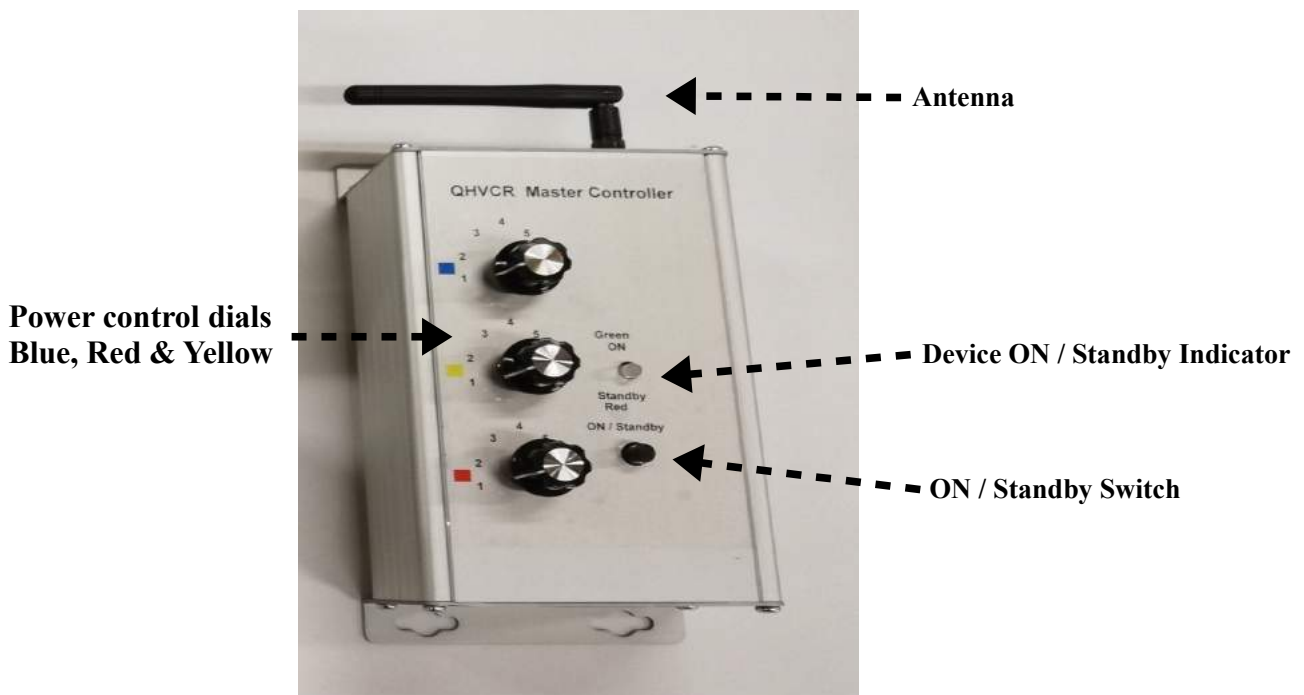

Fig 2

Quick Start for QHC18MR

See fig's 1,5 & 6

- 1) Start by removing the service hatch. Remove the 4 fixing screws, 2 at the top and 2 in the corners. There is a Din Rail revealed once the service hatch has been removed.
- 2) Use the cable grommets to bring the cables into and out of the controller base .
- 3) Connect the Mains IN as follows, Neutral blue wire to terminal #1 – **Neutral IN**, Live **Brown** wire to terminal #2 – **L1 IN**, Live **Black** wire to terminal #3 – **L2 IN**, Live **Grey** wire to terminal #4 – **L3 IN** see fig 5.
- 4) There are two methods on how to connect the Infrared Heaters to the controller.
 - a) Connect the heater or heaters Live to O/P1 terminal #5 **switched L1**, the O/P has a maximum load capacity of 6kW or 32amps. O/P1 can also be referred to as Zone 1. Connect the heater Neutrals to **Neutral Out** terminals #8 – 13. The heater Earth is connected to the **Earth** terminal #14. The remaining heaters should be distributed across the remaining two outputs O/P2 & O/P3.
Please ensure that the load is balanced across the output terminals #5 – 7.
Do not exceed the maximum load capacity per output.
 - b) Connect to an external distribution box. Connect O/P1 to terminals marked **1**, O/P2 to terminals marked **2** and O/P3 to terminals marked **3**. Connect the Neutral OUT to the blue terminals marked **N**. Connect the Earth to the green/yellow **Earth** terminals. Then connect the heaters to the other side of the terminals to the appropriate connections. **Live** connections to terminals **1,2&3**. **Neutral** connections to blue terminals **N** and **Earth** connections to the **Earth** terminals. See fig 6.
- 5) When all connections are complete and connected correctly, check once again that the wiring is correct as per 3) & 4). Then replace the service hatch cover and tighten the fixing screws.
- 6) Turn ON or reconnect the Main Power to the controller. The red neon lamp on the front panel will illuminate to indicate that the unit is **LIVE**.
- 7) There are auxiliary devices such as mains operated PIR motion detectors & timer (lag) switches. These can be connected to terminals #15 – 17. External push button switches which are voltage clean or free can be connected to terminals #18 – 20. Go to pages 7,8 & 9 and see fig's 9 to 12.
- 8) **Remote** operation ensure the Power control dial is in position **R**. Follow the instructions in page 3 for **QHVCr remote Master Controller** .
- 9) **Manual** operation move the position of the dial through positions **M, 1, 2, 3 & 4**.
M = 0%, 1 = 33%, 2 = 50%, 3 = 66%, 4 = 100% see fig 3.

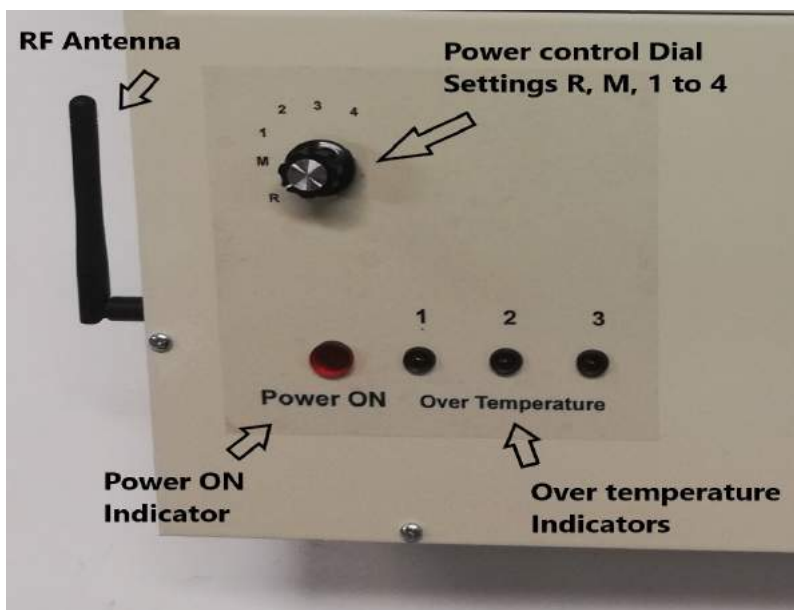

Fig 3

Remove wire links white, yellow & red.



Fig 4

IMPORTANT

If wire links or external push button switches are not fitted the unit will not operate when S2 is in the ON position. See fig 4 &

Controller Setup Manual Operation S1 & S2

To access S2, remove both the service hatch & front panel.

S2 is found on the printed circuit boards QHPCB-A. There is a set on each board. See fig. 8

PIR & External Switches OFF - S2 Slide switch is set in the Off position (select 2), factory set.

Set up for use with PIR's & External Switches – S2 Slide switch must be set in the ON position (select 1)

See fig. 8

S1 – Manual & Remote is controlled using the power control dial on the front panel. See fig. 1

This is set by turning the Power control dial to R (remote) or M (manual) control. There is a harness from the Power control printed circuit board on the front panel down to S1 Remote control ON/OFF header of each QHPCB-A board on the controller base. See fig 16 page 10.

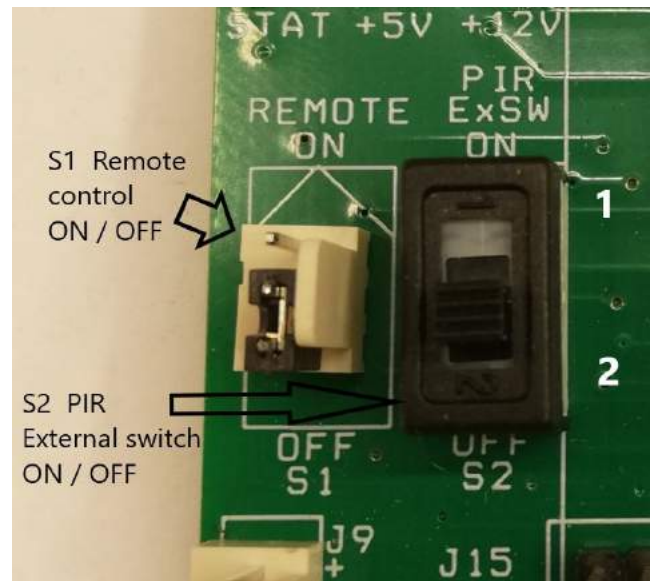
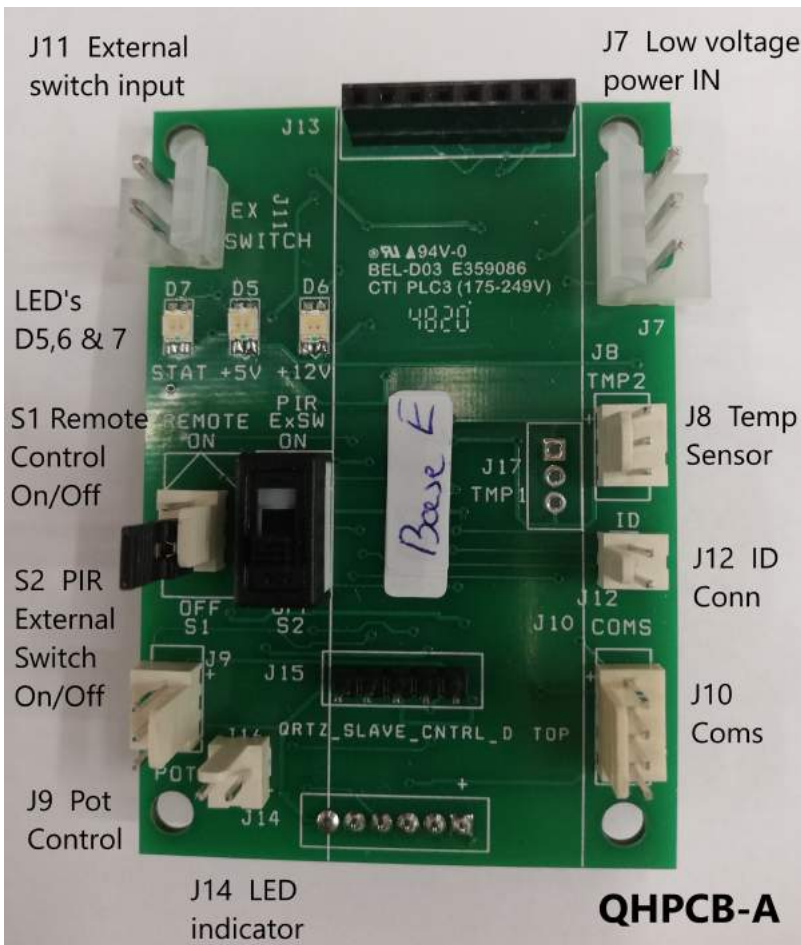

Fig 8

Fig 7

LED's D5,6 & 7 on the PCB

These are bi-colour LEDs and indicate the status of the electronic board.

LED D7 marked STAT, will flash GREEN to indicate the board is running and the phase is detected. If the D7 LED was RED this indicates that the phase has not been detected and the board will not run.

LED's D5 (+5V) & D6 (+12V) are GREEN to indicate that the on board power supply +5v & +12v are both present and running. See fig. 7

QHVCr remote Master Controller (Transmitter)



Fig 9

Supplied separately

- 1) There are three control dials **Blue, Yellow & Red** one for each zone. The QHCxxMR units are preset to operate in one of these zones. The QHCxxMR unit once preset will only operate in that designated zone. The factory setting is 1, this will be the Blue control dial.
- 2) Turn ON the QHVCr unit by pressing the ON/Standby button on the front panel. The Led indicator will flash orange – green – orange – green and remain Green to indicate that the unit is ready see fig 2.
- 3) The QHCxxMR unit is preset as a Blue zone (1). Turn the Blue control dial to position **2**. The heaters connected to the QHCxxMR units will come ON at the minimum setting 33%. Continue to turn the Blue control dial through position **3** to **5** until you reach the desired setting. Settings are **1** = 0%, **2** = 33%, **3** = 50%, **4** = 66% & **5** = 100%.
- 4) QHCxxMR units which are preset to Yellow & Red zones are controlled by the Yellow & Red control dials respectively and will operate as above see fig 9.
- 5) The QHVCr unit is powered by **3 x AAA battery's**. The unit will automatically go into standby mode if the unit is inactive for more than 30 seconds. When the unit goes into standby mode all the QHCxxMR units will remain unchanged at the settings they were set at. Therefore the heaters will remain ON.
- 6) To change a setting just press the ON/Standby button and proceed as described in 2) & 3). However, while the QHVCr unit is ON, you can turn OFF all the heaters by pressing the ON/Standby button. This is indicated by the Led indicator flashing Red.
- 7) The previous settings will be remembered and will be restored when you press the ON/Stand by button again.

Please note: The QHVCr remote Master Controller can control any number of QHCxxMR controllers as long as they are within range, up to 100 meters * (see specification sheet for the QHVCr unit).

The QHVCr should be wall mounted.

* Longer antenna are available to extend the range up to 200 meters.

Pairing (Programming) Devices QHVCR & QHCxxMR

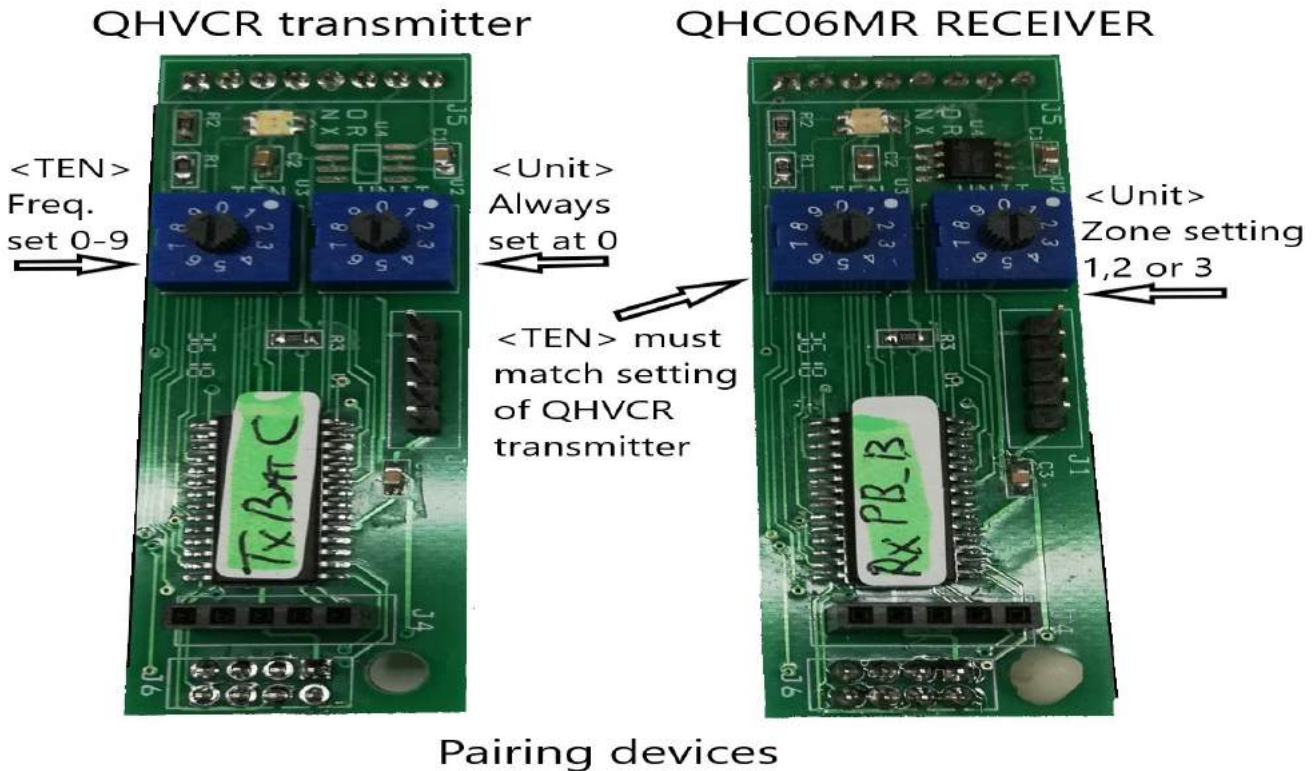

Fig 10

Pairing (programming) devices QHVCR (transmitter) and QHC18MR (receivers).

- 1) The Left Hand Side rotary switches (TEN) on both boards must be set the same. The LHS switch (TEN) is used to set the RF frequency the setting must match on both boards. There are 10 possible frequencies that can be selected 0-9. If the settings on the LHS switch (TEN) do not match the devices will fail to operate.

Designating the transmitter and receiver. Both the left rotary switches are set at 0, this ensures that the transmitter marked 0 will communicate with the receiver marked 0. Setting the left rotary switch to 1, so the transmitter marked 1 will communicate with a receiver also marked 1.

If the transmitter and receiver are not paired correctly they will not communicate and therefore will not operate; transmitter marked 0 will **not communicate** with a receiver marked 1.

Remember a transmitter can be set at any number between 0-9 & the receiver must be matched correctly.

- 2) The Right Hand Side rotary switches (UNIT) are for setting the device to operate in a set zone. There are 3 possible zones that the controller can be set to. The RHS switch (UNIT) should be set to 1,2 or 3.

Blue Zone 1 operation set RHS switch (UNIT) to 1

Yellow Zone 2 operation set RHS switch (UNIT) to 2

Red Zone 3 operation set RHS switch (UNIT) to 3

See fig 10.

Note : QHCxxMR = QHC03MR, QHC06MR or QHC18MR

PIR Motion Detectors Connection & Operation

PIR motion detectors are passive infrared sensors, an electronic device which is triggered by infrared light from the movement of objects in its field of view.

We recommend the QHPIR is used with our QHC controllers.

When using a PIR – S2 slide switch must be in the ON position (select 1). See fig 8 page 4. Remember there are 3 zones, Blue Yellow & Red. Connect the Switched Live Out trigger L' to the PIR input terminal #15, 16 or 17 for separate control of each zone. Only 1 PIR per zone can be connected. **Blue zone = #15, Yellow zone = #16 & Red zone = #17.** See fig's 6, 7 & 8.

For single PIR operation, a jumper link can be fitted connecting the 3 inputs (terminals 15,16 & 17) together. In this configuration **1 PIR** will turn ON all 3 zones together.

The **PIR** when triggered, will also trigger the controller and turn on the appropriate zone. The ON time will depend on the time set on the PIR. This is found on the underside of the PIR housing. Note: **PIR ON** time is adjustable from 5 seconds to 15 minutes.

Note: a PIR should not be located directly in front of an Infrared heater. The infrared light emitted from the heater will keep the PIR permanently triggered and the motion detector will fail.

Please follow the instructions provided with the PIR for installation and connection.

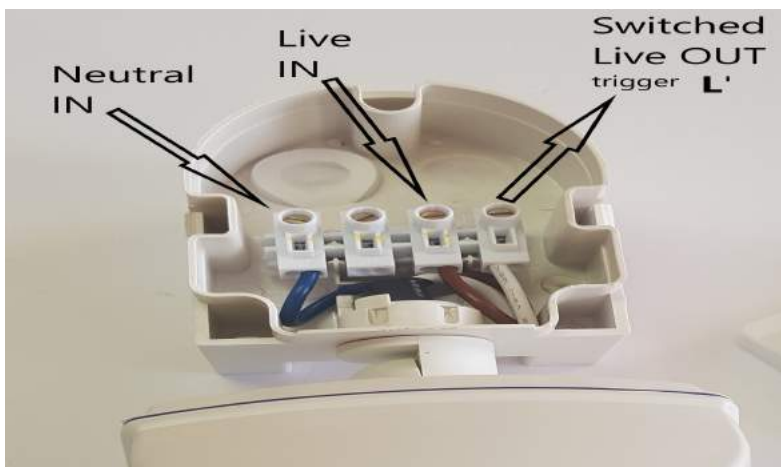

Fig 11



Fig 12

External Switch Connection & Operation

Push On/Push Off & Timer (10 minute) function

External switches can be connected to the controller via terminals #18,19 & 20 a+b. This particular terminal is a Double deck terminal. The switch must be a normally open contact switch (NO) and contacts must be voltage free.

When using External Switches – S2 slide switch must be in the ON position (select 1). See fig 8 page 4. Remember there are 3 zones, Blue Yellow & Red. Connect the switch contacts across the input terminals #18,19 or 20 a+b for separate control of each zone. See fig 13. Only 1 external switch can be connected per zone.

For single external switch operation, a link bar with mount screws can be fitted connecting the 3 input (terminals #18,19 & 20) together. In this configuration 1 External Switch will turn ON all 3 zones together. See fig 14 & 15.

When the external switch contacts are closed this will trigger the controller and turn ON the appropriate zone. The external switch controls the Push ON/Push OFF or Timer function for each zone.

The Push ON/Push OFF or Timer functions are pre-programmed and must be specified prior to manufacture.

Fig 13

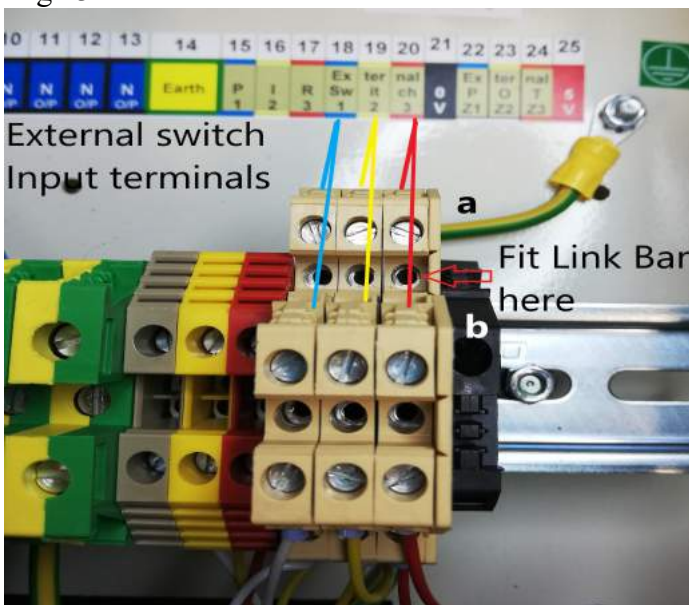

External Switch Input terminals 18,19 & 20 a+b

Fig 14

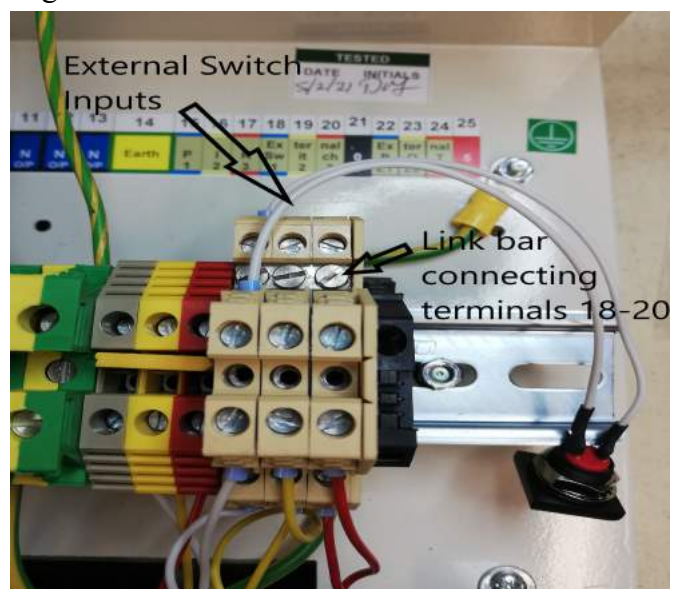

Link bar fitted across the 3 inputs 18,19 & 20
Also shown above with test push switch

Using a PIR or an External switch to control several controllers at once is possible. If all the outputs are required to operate as one output. Use the jumper link in the case of the PIR and the link bar for the External switch. PIR example, connect a jumper link across terminals #15,16 & 17. This turns the 3 inputs into 1 input. So, one PIR L' trigger input will now control all 3 outputs. If the same terminals #15,16 & 17 on several other controllers are also connected in the same way using a jumper link. Then run a cable one wire between each controller connecting each set of terminals #15,16 & 17 together. This setup will now allow several controllers to be controlled by one PIR motion detector.

Note: Important this L' trigger is a live connection and the appropriate wire must be used.

External switch example, this time use the Link bar to connect across terminals #18a,19a & 20a. This connection is voltage free so standard signal wire can be used. Connecting the set of terminals on each controller together allows for one External switch to again control several controllers at once.

Jumper Link (PIR) & Link Bar (External switch)

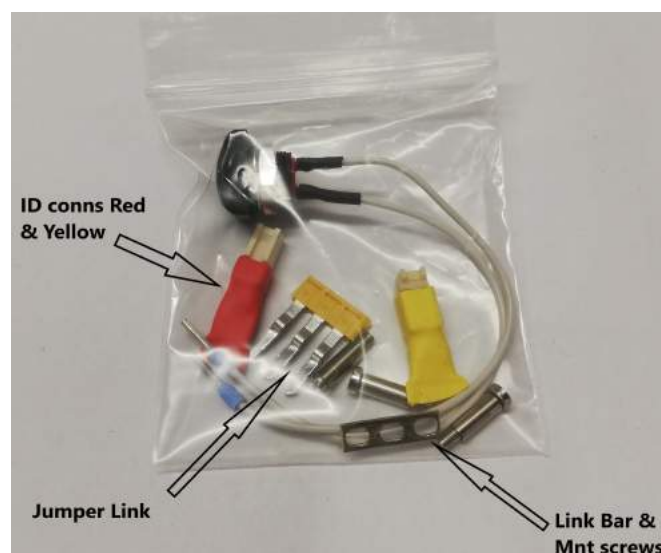
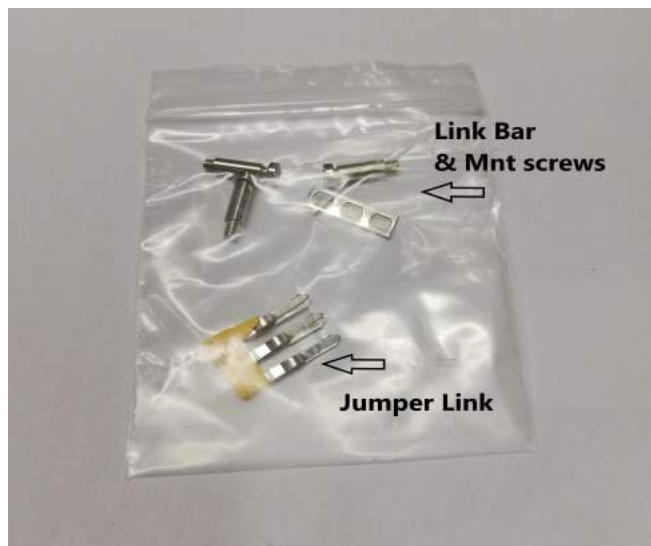

Jumper Link fitted to inputs #15-17 (PIR) & Link Bar fitted to inputs #18-20 (External switch)

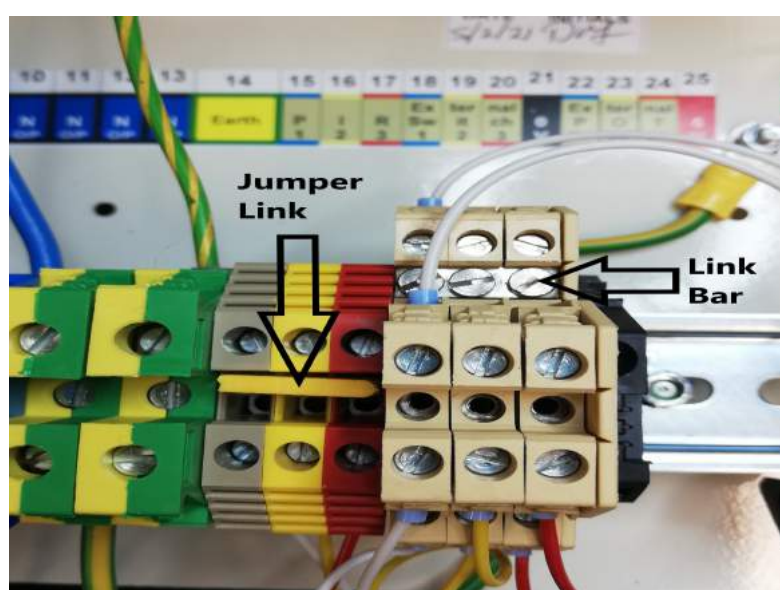

Fig 15

Connecting the Jumper Link to inputs terminals #15-17 allows for one PIR to control the unit. Connecting the Link Bar to inputs terminals #18-20 allows for one external switch to control the unit.

Over Temperature Protection

There are 3 temperature sensors and 3 LED indicators one for each zone. The LED indicators are located on the front panel marked 1, 2 & 3. When an over temperature situation is detected one of these will flash to indicate which zone has over heated. The controller will automatically reduce the power to the affected zone to 50%. (Note this is provided the initial setting is already greater than 50%). With the power reduced the temperature should return to normal working temperature.

If however after 30 minutes this does not happen and the over temperature indicator is still flashing. The controller will automatically shut down (turn OFF) the affected zone, allow the zone to cool down for another 30 minutes. The remaining unaffected zones will continue to work normally. Reset the unit by switching OFF and then back ON using the mains isolation for the controller to recover.

If the over temperature condition persists you are advised to turn off the zone using the appropriate MCB on the front panel and call a qualified electrician to address the problem.

Fitting ID Connectors Red & Yellow

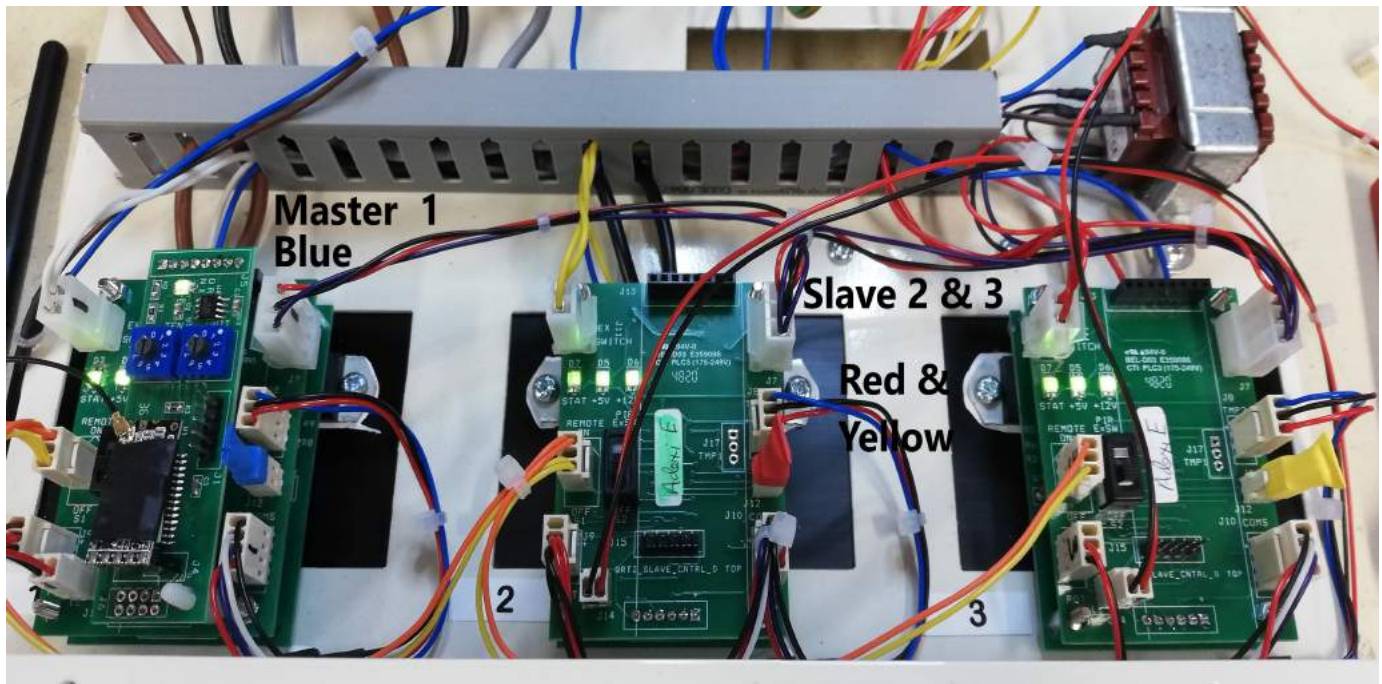

Fig 16

Master 1 printed circuit board (PCB) is located in position 1, phase L1. This is the main board that controls the entire QHC18MR controller. The **Slave 2 & 3** pcb's are located in positions 2 & 3, phases L2 & L3.

The Master 1 pcb is fitted with the receiver pcb & antenna for communications with the QHVCR transmitter, also fitted is the blue ID connector connector header J12 ID Conn, see fig 17. This blue ID connector is very important, if this is not fitted the unit will not operate in remote mode. It is also important that the communications harness between all three pcb's is also fitted. This is essential for the Master to communicate with the two Slave pcb's, the harness is connected to J10 Coms, see fig 17.

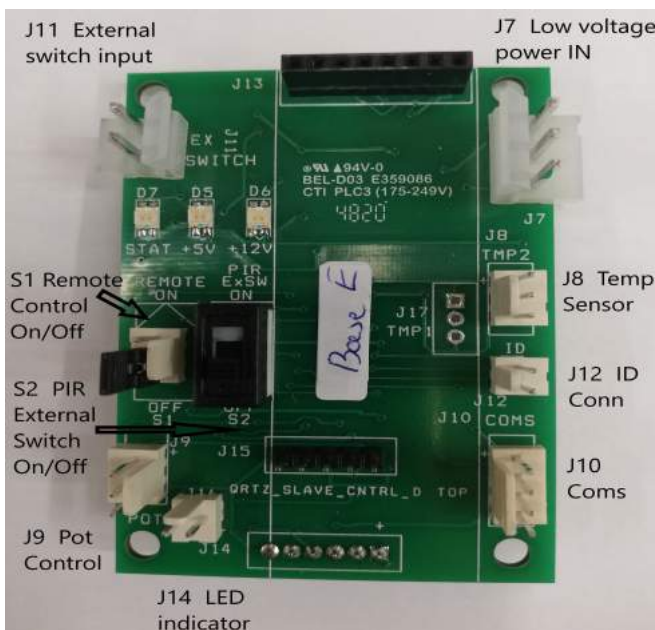

Fig 17

Normal default configuration leaving the factory is the blue master ID connector is fitted to the Master 1 pcb. In this configuration all three outputs will behave as one.

To pair the controller & set the Zone with the QHVCR see fig 10 page 6 and follow steps 1) & 2).

If however you want to set the 3 outputs as 3 separate zones in the one controller as above in fig 15.

You must set the Right hand rotary switch (Units) to position **0** and then fit the Red & Yellow ID connectors to J12 on each pcb's 2 & 3 see fig 16.

Using the QHVCR transmitter you now control each output separately.

These Red & Yellow ID connecting are supplied as extras.

Supply voltage : Three Phase 415V AC 50/60 Hz

All O/P's with Soft start

Max. Load capacity: 18 kilo Watts * (Load must be balanced across all 3 outputs max 6Kw each)

Over Temperature Protection: On each O/P - Led indicators 1,2 & 3

Mains I/P :	Neutral (Blue)	terminal #1
	Live 1 (Brown)	terminal #2
	Live 2 (Black)	terminal #3
	Live 3 (Grey)	terminal #4
Mains O/P :	Switched Live 1 (Brown)	terminal #5
Soft start	Switched Live 2 (Black)	terminal #6
	Switched Live 3 (Grey)	terminal #7
	Neutral return out (Blue)	terminal #8-13
	Earth out (Green/Yellow)	terminal #14
PIR I/P :	Live trigger input Zone 1	terminal #15
Auxiliary	Live trigger input Zone 2	terminal #16
Device	Live trigger input Zone 3	terminal #17
Ext. Sw. I/P :	Ext. SW1 Zone 1	terminal #18 a+b
Auxiliary	Ext. SW2 Zone 2	terminal #19 a+b
Device	Ext. SW3 Zone 3	terminal #20 a+b
QHVC-S I/P :	0V	terminal #21
Auxiliary	Zone 1	terminal #22
Device	Zone 2	terminal #23
Optional	Zone 3	terminal #24
	5V	terminal #25

IP Rating: IP53

Dimensions : 350mm x 330mm x 150mm

Weights : QHC18MR – 10 Kg

Note : Terminal connections are the same for both the QHC18M & QHC18MR controllers.

HEAT
outdoors

Tel. 01279 466 500 Email: info@heat-outdoors.co.uk

Website: www.heat-outdoors.co.uk

Unit 9 Stort Valley Industrial Estate, Bishop's Stortford, Hertfordshire, CM23 2TU, UK